

COOLING SYSTEM

Cooling System Features

- The coolant pump can be serviced without disconnecting radiator hoses.
- Both the glow plug sleeves and the injector sleeves are stainless steel.

Cooling System Features

- Coolant Pump
- Stainless Steel Injector Sleeves
- Stainless Steel Glow Plug Sleeves

24

Internal Coolant Flow

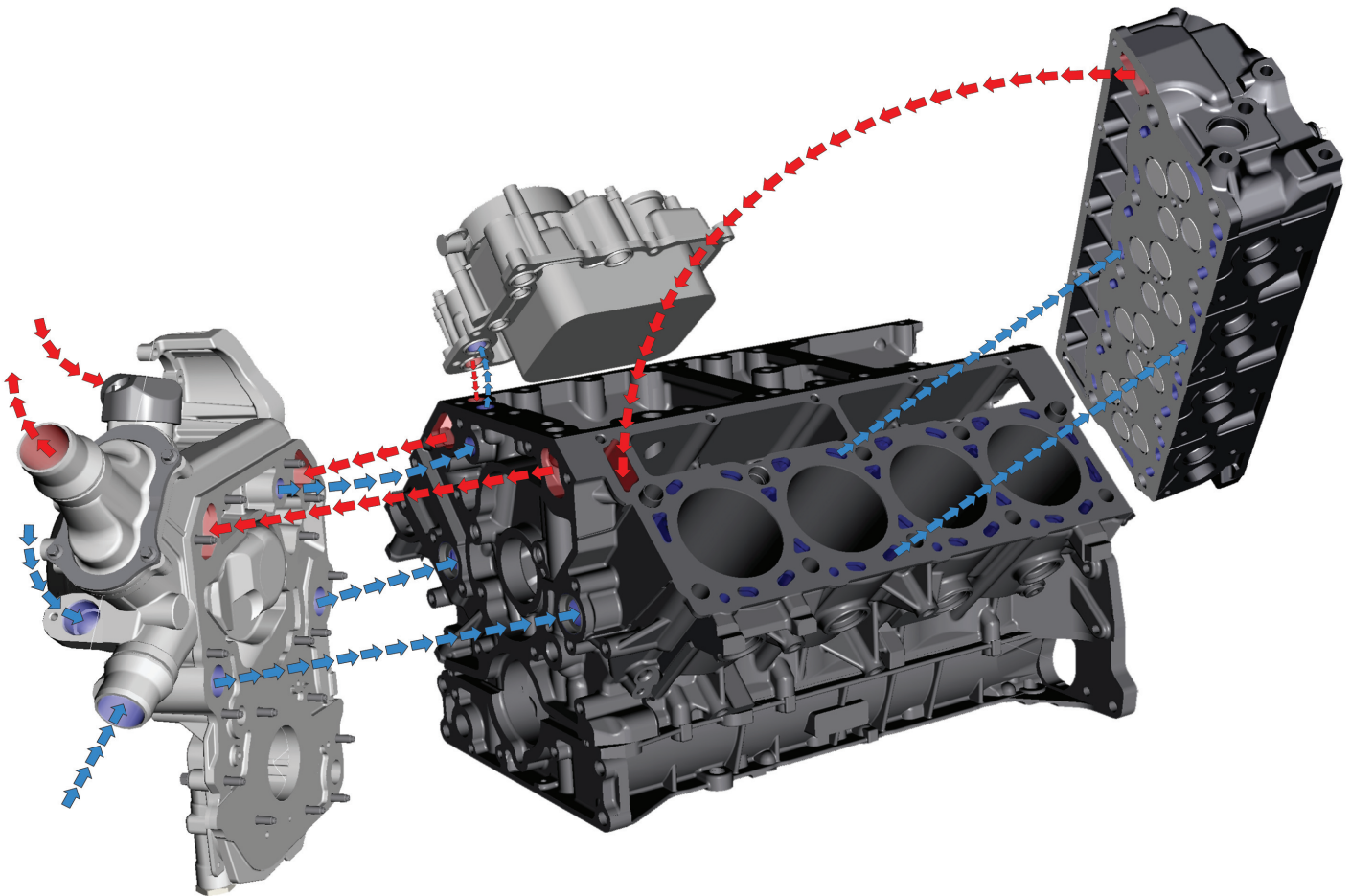

25

COOLING SYSTEM

External Coolant Flow

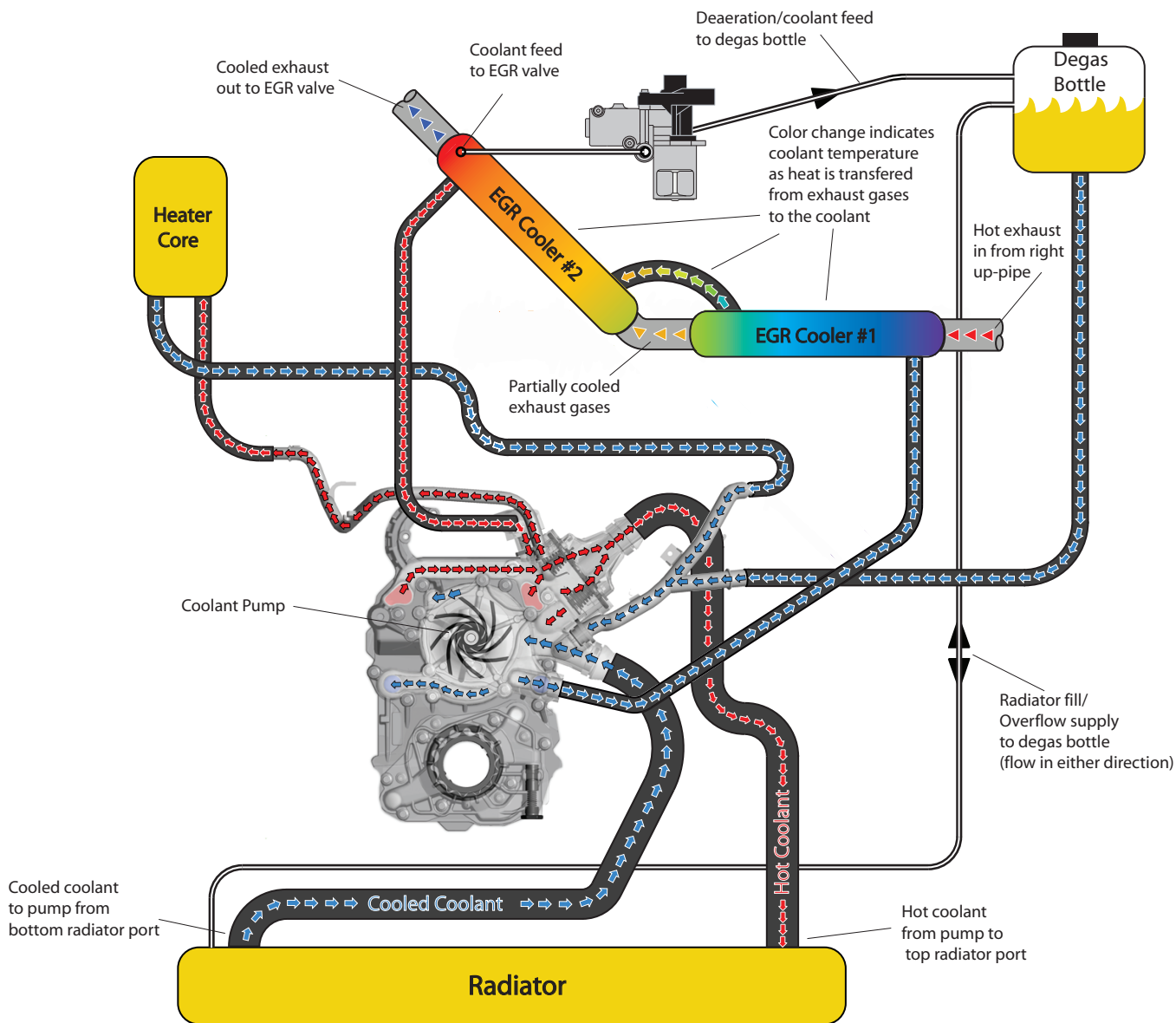

Cooling System Flow: External Flow

- Coolant is drawn into the inlet of the front cover from the bottom radiator port and then flows from the coolant pump through the front cover to the crankcase.
- Coolant is also routed from the front cover into the crankcase to a passage that feeds the oil cooler (shown on next page).
- Coolant is routed from the front cover to the EGR coolers, EGR valve, degas bottle, and the vehicle heater core.
- The horizontal EGR cooler receives coolant first, then the coolant travels to the vertical EGR cooler through a short connection hose. Hot coolant exits the vertical EGR cooler at the top and enters into the front cover.
- A port next to the hot EGR return port in the front cover routes hot coolant to the heater core for vehicle heating. The coolant then travels to a Y-pipe where it meets with degas return coolant before being sent into the front cover, just above the main coolant inlet from the radiator.
- The EGR valve receives its coolant from a passage at the top of the vertical EGR cooler. Once the coolant exits the EGR valve it is sent to the degas bottle (this passage is the highest point in the system and is also the deaeration port).
- The port directly below the EGR valve return/deaeration port on the degas bottle is used as a radiator fill/overflow line connecting with the top of the radiator.
- A dual thermostat system is used to control the flow of return coolant to the radiator. If the thermostats are open, coolant flows to the radiator to be cooled. The bottom thermostat has a bypass circuit that will allow coolant to return to the pump when the thermostats are closed (speeding engine warm up).

COOLING SYSTEM

Cooling System Flow: Back of Front Cover

- Coolant is sealed via a metal one piece gasket and is directed out of the front cover through three (3) passages.
- Two of the passages route coolant to the crankcase to cool the cylinder walls and cylinder heads (there are different sized orifices pressed into the crankcase in these two passages).
- The third passage routes coolant to the oil cooler via a passage in the crankcase.
- There are two passages for coolant to return from the crankcase into the front cover.

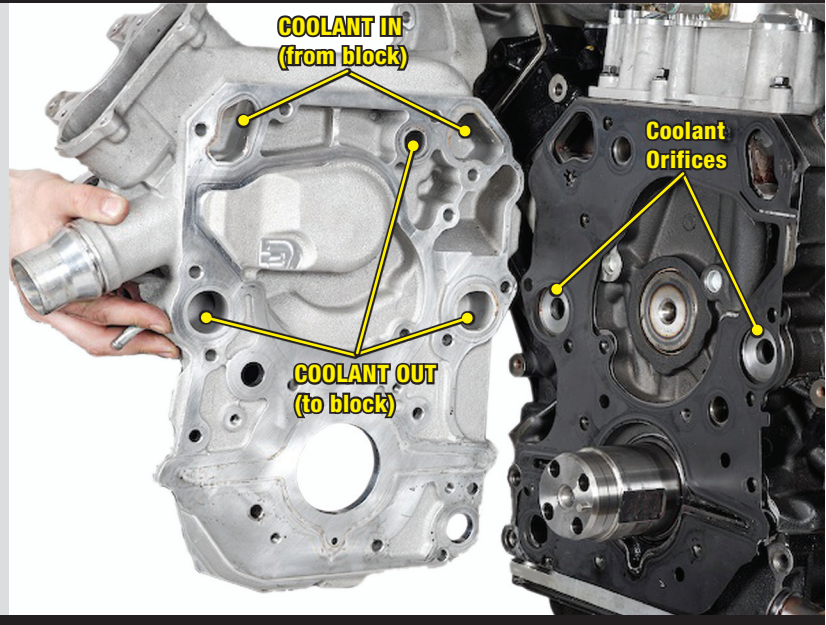

Oil Cooler Coolant Flow

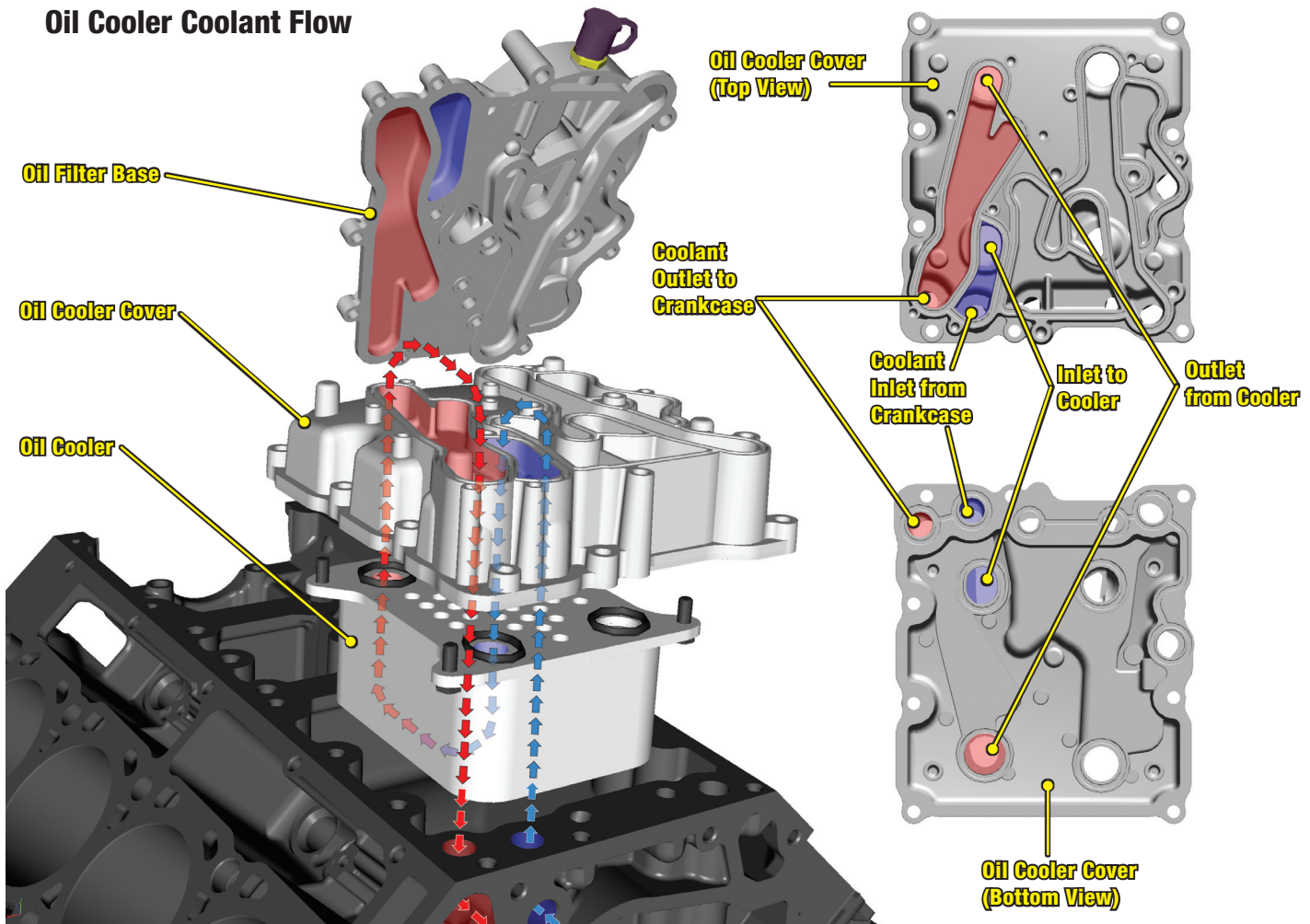

Cooling System Flow: Oil Cooler

- Coolant is directed out of the crankcase and into the oil filter base at the front of the engine.
- The oil filter base routes the coolant down into the front of the oil cooler then toward the rear of the engine.
- Once the coolant has passed through the oil cooler it is routed up to the top of the oil cooler then directed towards the front through a port where it is then routed down, out of the cooler, through a port in the block.

COOLING SYSTEM

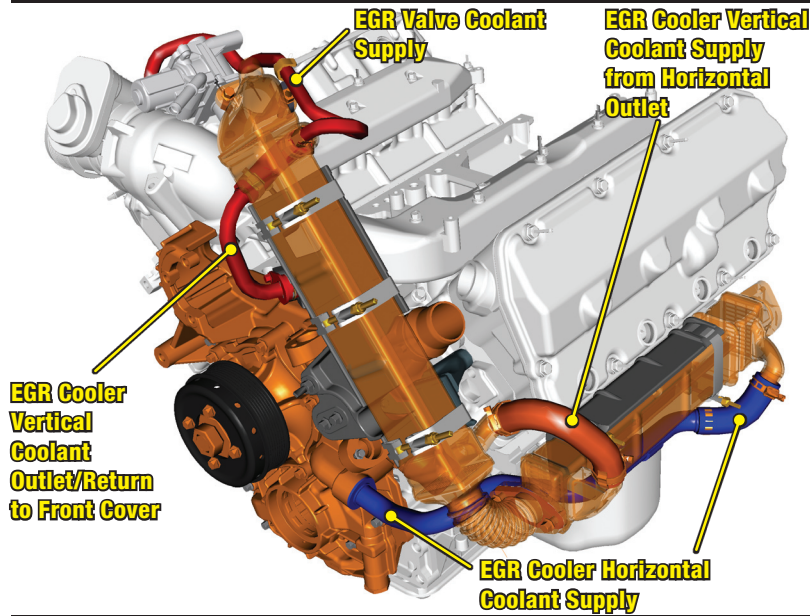

Cooling System Flow: EGR Coolers

- Cooled coolant flows out of the supply port of the front cover where it is routed to the horizontal cooler at the left rear side of the engine.
- The coolant then exits the horizontal cooler and is immediately routed into the vertical cooler. The coolant then exits the vertical cooler where it is routed to the return port in the front cover.
- There is a small port at the top of the vertical cooler where coolant is allowed to flow to the EGR valve, cool the valve, then the coolant is routed to the degas bottle. This port is also used as the deaeration port.
- Coolant flows through the EGR coolers and removes heat from the exhaust before the exhaust arrives at the EGR valve.

28

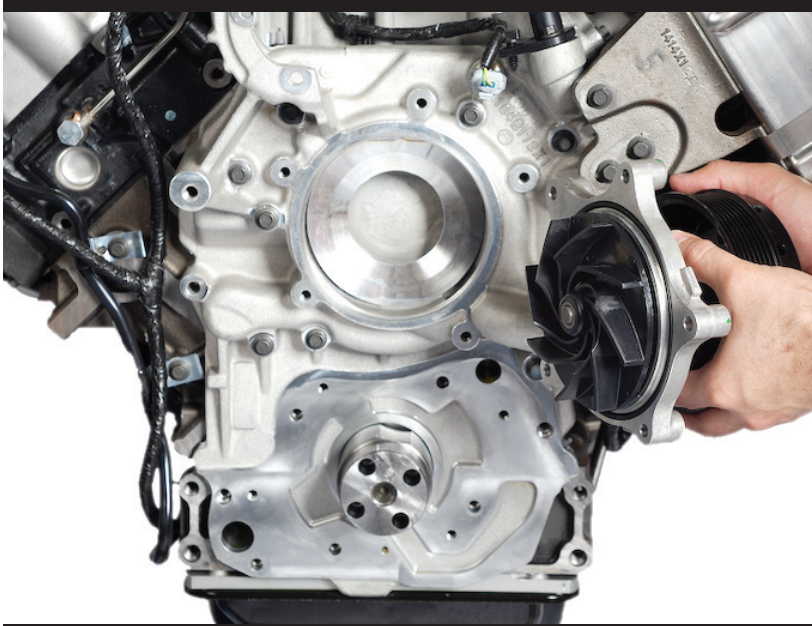

Coolant Pump & Front Cover

- The coolant pump, (hub and impeller) is mounted into the front cover which is the housing for the water pump.
- The coolant pump impeller pulls coolant from the center of the housing and pushes it outward.
- The coolant pump has a built in reservoir to catch small amounts of coolant that during normal operation of the engine may seep past the seal. This coolant will evaporate over time.

Note: The coolant pump impeller may be damaged if dropped or hit by a hard object.

29

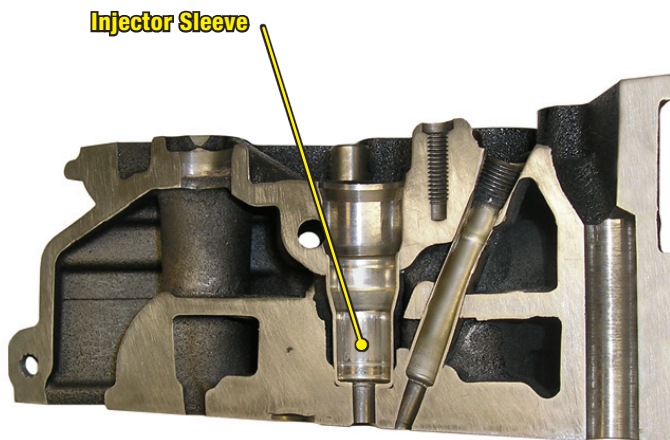

Injector Sleeve

- The 6.4L Power Stroke uses stainless steel injector sleeves to seal coolant from the injector and to transfer heat from the injector to the coolant.
- The injector sleeve is replaceable.

30

COOLING SYSTEM

Glow Plug Sleeve

- Glow plug sleeves are used to keep coolant from coming in direct contact with the glow plugs and to seal coolant from the combustion chamber.
- The glow plug sleeve is replaceable. See unique service procedures or the service manual for more details.

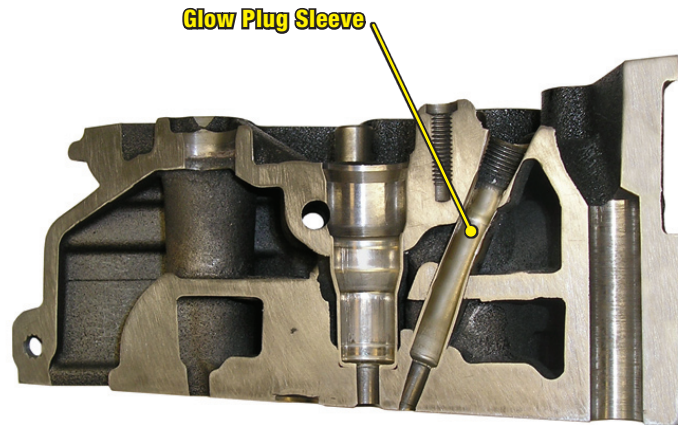

31

Degas Bottle

- The degas bottle is located on the left side of the engine compartment and is part of the left side battery tray.
- One of the ports on the bottle is attached to the EGR valve coolant line (which is supplied from the top of the vertical EGR cooler). If this port or hose is blocked, damage could occur to the EGR coolers and/or the EGR valve.



32